



ST-2XX // TEMPERATURE & HUMIDITY TRANSMITTER / NT-2XX // HUMIDITY TRANSMITTER

DUCT TYPE

- Accurate and Precise Measuring
- Analog Output
- Long Operating Life
- Cleanable Filter
- Easy Assembling
- IP 67 Plastic Case (Not Including Sensor)



TECHNICAL SPECIFICATIONS

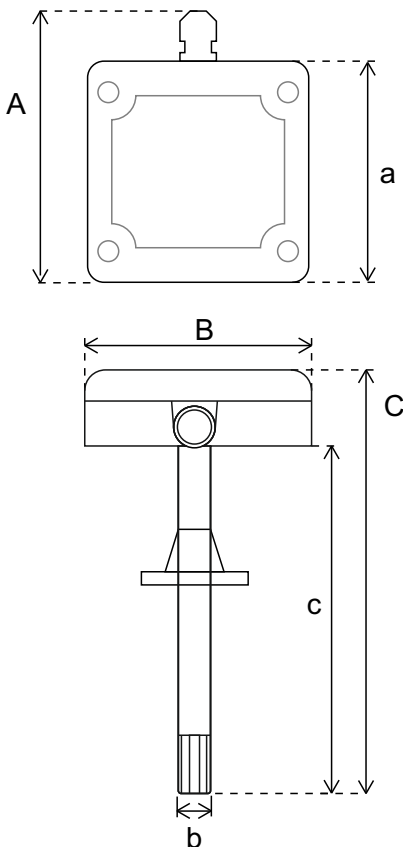

Product Informations	
Product Name	ST-2XX Temperature & Humidity Duct Type Transmitter NT-2XX Humidity Duct Type Transmitter
Input	12-24 V DC

Sensor	Output Range	Sensitivity	Accuracy
Temperature	0 - 50°C / -20...+80 °C -40...+80 °C	± 0,1 °C	± 0,3 °C
Humidity	0 - 100 % RH	± 1 % RH	± 3 % RH

Product Code	Output Signal	Dimensions		
		A	B	C
ST-201 / NT-201	0-10 V / 2-10 V / 0-3 V	102 mm	80 mm	229 mm
ST-241 / NT-241	4-20 mA / 0-20 mA	a	b	c
ST-261 / NT-261	Modbus RTU	80 mm	15 mm	191 mm