



ST-2XX // TEMPERATURE & HUMIDITY TRANSMITTER / NT-2XX // HUMIDITY TRANSMITTER

DUCT TYPE

- Accurate and Precise Measuring
- Analog Output
- Long Operating Life
- Cleanable Filter
- Easy Assembling
- IP 67 Plastic Case (Not Including Sensor)



TECHNICAL SPECIFICATIONS

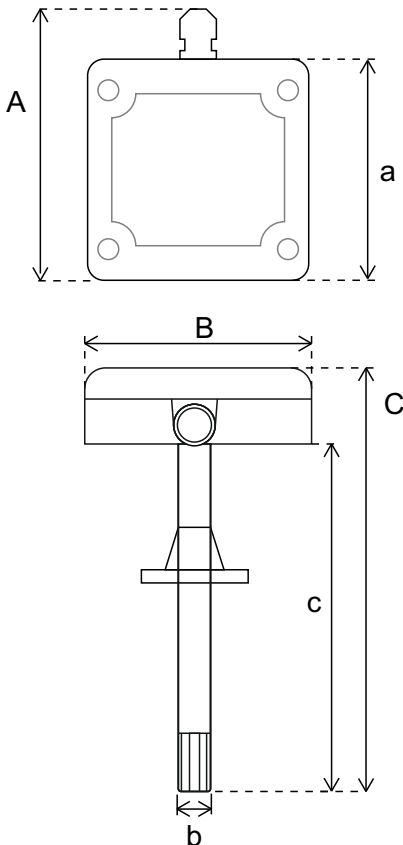

Product Informations	
Product Name	ST-2XX Temperature & Humidity Duct Type Transmitter NT-2XX Humidity Duct Type Transmitter
Input	12-24 V DC
Output	0-10 V / 4-20 mA / Modbus RTU

Sensor	Measuring Range	Sensitivity	Accuracy
Temperature	0 - 50°C / (-20) - (+80)°C	± 0,1 °C	± 0,3 °C
Humidity	0 - 100 %	± % 1	± % 3

Product Code	Output Signal
ST 201 / NT 201	0-10 V
ST 241 / NT 241	4-20 mA
ST 261 / NT 261	Modbus RTU

Dimensions		
A	B	C
102 mm	80 mm	229 mm
a	b	c
80 mm	15 mm	191 mm