

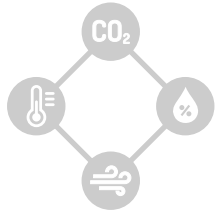

**PANEL TYPE GAS CONTROL DEVICE**

**AR/CR/ER/OR-711 USER MANUAL**



www.emskontrol.com

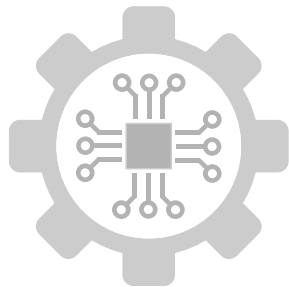

**WHAT IS IT?**

Panel type gas control device allows you to control your gas devices in the desired value range by precisely measuring the gas value.

**HOW DOES IT WORK?**

Operates with 220 V AC supply. Depending on your gas device, you can control your devices with the help of our direct control device or contactor.

**GENERAL FEATURES**

Accurate and Precise Measuring, 1 Relay Output, Durable and Handy Design, 2 Years Sensor Operating Life, Easy Replaceable Sensor, Panel Type Mounting, Adjustable Relay Sensitivity

**AREAS OF USE**

HVAC Applications, Poultry Automation and Poultry Farms, Cold Storage, Incubation Rooms, Food Storage, Air Conditioning Cabinets, Clean Rooms and Laboratories.

**RULES TO BE CONSIDERED FOR SAFETY**

- 1- Always read the user manual before using the device and its apparatus.
- 2- Damages caused by opening, breaking or misuse of the plastic parts of the device and its apparatus are considered out of warranty.
- 3- Keep the device and its apparatus away from external influences such as liquid, high dust, high temperature, etc. and protect them.
- 4- Do not expose the device cables to any jamming and pressure.
- 5- Disconnect the electrical power when your device is not used for a long time.
- 6- Our devices and apparatus should be used by paying attention to the points in the user manual. In case of damages and malfunctions arising from external use (liquid contact, falling to the ground, etc.) ask for help from the service.
- 7- Failures due to electrical connection errors and electrical voltage or current errors are not covered by the warranty.

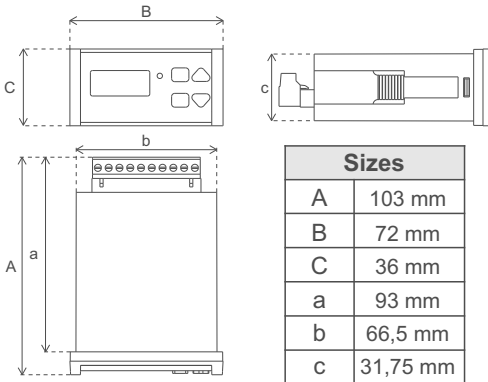

Technical Data	
Product Name:	Panel Type Gas Control Device
Supply Voltage:	220 V AC
Output:	Relay (2A)
M. Range (NH <sub>3</sub> ):	0-100 ppm
Precision (NH <sub>3</sub> ):	± 1 ppm
Accuracy (NH <sub>3</sub> ):	± 2 ppm
M. Range (CO):	0-1.000 ppm
Precision (CO):	± 1 ppm
Accuracy (CO):	± 5 ppm
M. Range (C <sub>2</sub> H <sub>4</sub> ):	0-10 ppm / 0-100 ppm
Precision (C <sub>2</sub> H <sub>4</sub> ):	± 0,1 ppm
Accuracy (C <sub>2</sub> H <sub>4</sub> ):	± 0,3 ppm
M. Range (O <sub>2</sub> ):	0-25 % VOL
Precision (O <sub>2</sub> ):	± 0,1 % VOL
Accuracy (O <sub>2</sub> ):	± 1 % VOL
Operating Temperature:	(-10°C) - (+55°C)
Storage Temperature:	(-20°C) - (+60°C)
Protection Class:	IP 67 (Excluding Sensor)

**INSTALLATION**

- 1- Unpack the product.
- 2- Make cable connections accordingly.

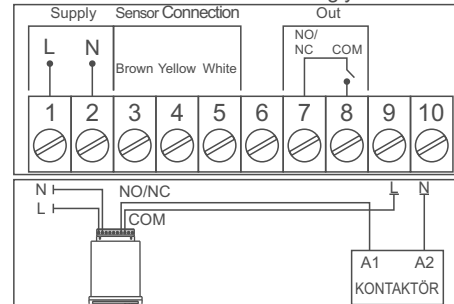

- 3- Place the product in the appropriate place on the panel.
- 4- After the product is energized, "OPEN" appears on the display for 30 seconds. It starts the measurement process after the "OPEN" text. It is recommended to leave the product in the environment for at least 5 minutes to get healthy measurement values.
- 5- It is recommended to use shielded cable as communication cable as it will prevent communication signals from being affected by external influences.
- 6- Since the communication cable will create resistance, check the measurement values again after cable installation.

**SET, HYSTERESIS and NO/NC VALUES**

When we press the "SET" button on the main screen, the first menu that appears in the SET menu. In this menu, the set value can be increased or decreased with the "UP" and "DOWN" buttons. When the "SET" button is pressed again, the HYS TERESIS menu is entered. The hysteresis value can be increased or decreased with the "UP" and "DOWN" buttons. When the "SET" button is pressed again, the manu where the relay positions are set appears. You can set "NC" with the "UP" button and "NO" with "DOWN" button. "BACK" button is used to go back in menus. If no button is pressed for 10 seconds while in a menu entered with the "SET" button, it returns to the main screen.

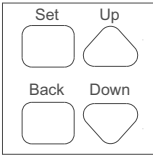

**WHAT IS "Err"?**

If no data is received from the sensor for about 15 seconds, an "Err" error appears on the display. In this case, check the sensor connection of the product.

**WHAT IS NO and NC?**

NO (Normally Open) opens the contact below the set value and closes the contact above the set value. NC (Normally Close) closes the contact below the set value and opens the contact above the set value.

**SET VALUE DISPLAY**

By pressing the "SET" button, you can view the last set value of the device.

**RELAY POSITION**

The green leds on the right side of the screen indicate whether the relay is open or closed. If the led is on, the relay is open, if not, the relay is closed.

**BEFORE CALIBRATION**

- 1- The product is sold as calibrated. Plase do not calibrate unless necessary.
- 2- Perform calibration only when it is certain that the product is measuring incorrectly.
- 3- Calibration is only performed at the production facilities. With the manufacturer for calibration please contact us.

**SENSOR LIFE - IMPORTANT CRITERIA**

- 1- Sensor life is 2 years. After 2 years, sensor replacement is required. Sensor replacement can be done easily in the field of use.
- 2- Do not expose the sensor to high amounts of natural gases. It may cause the sensor to malfunction.
- 3- The sensor energy connection should not be repeatedly switched on and off.

## USER MANUAL

### DECLARATION OF CONFORMITY

Headquarters and place of production, Halkapınar Mah. 1376 Sok. Boran Plaza No:1/L Konak / İZMİR - TÜRKİYE, EMS KONTROL ELEKTRONİK VE MAKİNE SAN. TİC. A.Ş. declares that the product marked with CE, whose name and specifications are given below, covers the specified directives and provisions.

Brand: EMS KONTROL  
Product Name:AR/CR/ER/OR- 711  
Product Type: Panel Type Gas Control Device

Compatible Directives:

Elektromagnetic Compatibility Directive  
2014/30/EU (EMC EN 61000-6-3: 2007 + A1: 2011, EN 61000-6-1: 2007)

Low Voltage Directive  
2014/35/EU (LVD EN 60730-2-9:2010, EN 60730-1:2011)

Additional information: This product can be used in combination with other devices and compliance with the directives covers only the product. EMS KONTROL is not responsible for the compliance of entire system with the directives.

This declaration is not valid if the product is modified without our approval.



**EMS KONTROL ELEKTRONİK  
VE MAKİNE SAN. TİC. A.Ş.**  
Halkapınar Mahallesi 1376 Sok. Boran Plaza  
No:1/L Konak / İZMİR  
EĞE V.D. 334 104 4628  
Mersis No 033410446280001

### WARRANTY TERMS

1- The warranty period of the devices and apparatus starts from the invoice date and is guaranteed for 2 years against manufacturing defects.

2- Devices and apparatus are delivered to the customer in working condition in our company. On-site commissioning is subject to service fee.

3- The repair of the devices and apparatus under warranty is carried out in our company as a result of sending them with the transportation company contracted by our company. In on-site services, transportation and accommodation expenses of the service personnel belong to the customer. The cost of the working time spent on the road is added to the service fee and the collection is made in advance.

4- Maintenance of devices and apparatus is done in our company. Transportation and transportation fees of the devices and apparatus to and from our company for maintenance belong to the customer.

5- In case of malfunction of the devices and apparatus whose warranty period continues, whether the malfunction is caused by the fault of the customer or the manufacturer is tested in our company and reported with the report to be issued by our company.

6- In case of detection of manufacturer-induced faults of the devices and apparatus whose warranty period continues, the customer may request a replacement or may request that the repair costs of the devices and apparatus be fully covered by the manufacturer, provided that it does not exceed the product price.

7- In the event that the faults of the devices and apparatus whose warranty period continues are determined to be caused by the customer, all costs belong to the customer.

8- If the customer does not indicate that he/she is aware of the defects in the devices and apparatus from the date the warranty period starts or in cases where he/she is expected to be aware, he/she cannot benefit from Article 6.

9- Failures arising from the use of devices and apparatus contrary to the points in the user manual are not covered by the warranty.

10- Devices and apparatus are not covered by the warranty if they are beaten, broken or scratched by the customer.

11- Damages caused by the use of devices and apparatus of other brands and models without the approval of the manufacturer are not covered by the warranty.

12- Errors caused by rusting, oxidation and liquid contact due to working in dusty / acidic / humid environments are not covered by the warranty.

13- Damages that may occur during transportation of devices and apparatus are not covered by the warranty. If the customer wishes, he/she can have transportation insurance.

14- Damages caused by mains voltage / faulty electrical installation are not covered by the warranty.

15- Devices and apparatus are not covered by the warranty in case of malfunctions caused by force majeure such as fire, flood, earthquake, etc.

16- All parts of the devices and apparatus, including all parts, are covered by our company's warranty.

17-If the devices and apparatus malfunction within the warranty period, the time spent in repair shall be added to the warranty period. The repair period of the goods shall not exceed 20 working days. This period starts from the date of notification of the malfunction of the goods to the service station, in the absence of a service station, to the seller, dealer, dealer, agent, representative, importer or manufacturer - manufacturer of the goods. It is possible for the consumer to notify the malfunction by telephone, fax, e-mail, registered letter with return receipt or similar means. However, in case of dispute, the burden of proof belongs to the consumer. If the malfunction of the goods is not resolved within 20 business days, the manufacturer-manufacturer or importer; until the repair of the goods is completed, another goods with similar characteristics must be allocated to the use of the consumer.

18- Despite the consumer's right to repair the goods; -Provided that it is within the warranty period from the date of delivery to the consumer, it fails at least four times within a year or six times within the warranty period determined by the manufacturer-manufacturer and / or importer, as well as the fact that these failures make the inability to benefit from the goods continuous, -Exceeding the maximum time required for repair, -If it is determined that it is not possible to repair the malfunction with the report to be issued by the service station of the company's service station, if the service station is not available, respectively by one of its dealer, dealer, agency, representative, importer or manufacturer-manufacturer, it may request a refund or a price reduction at the rate of defect.

19-Customer may file complaints and objections to consumer courts or consumer arbitration committees.

20-The warranty certificate must be kept by the customer during the warranty period. In case of loss of the document, a second document will not be issued. In case of loss, repair and replacement of devices and apparatus will be made for a fee.



This device is a Waste Electrical and Electronic Device according to the directives applied in Europe 2002/96/EC. (WEEE) Before scrapping or throwing away this device, you must prevent its potential negative consequences for the environment and human health. Otherwise it would be inappropriate waste. This symbol on the product is intended to warn that the product should not be treated as household waste and should be delivered to electrical and electronic waste collection points. Disposal of the product must be done in accordance with local environmental regulations. You can obtain detailed information from authorized units on how to destroy, reuse and recycle the product..

#### Manufacturer's

Title: EMS KONTROL ELEKTRONİK VE MAKİNE SAN. VE TİC. A.Ş.

Address: Halkapınar Mah. 1376 Sokak Boran Plaza No:1/L Konak / İzmir-TÜRKİYE  
Telephone: 0 (232) 431 2121  
E-Mail: [info@emskontrol.com](mailto:info@emskontrol.com)

Company Stamp:

**EMS KONTROL ELEKTRONİK  
VE MAKİNE SAN. TİC. A.Ş.**  
Halkapınar Mahallesi 1376 Sok. Boran Plaza  
No:1/L Konak / İZMİR  
EĞE V.D. 334 104 4628  
Mersis No 033410446280001

#### Product's

Type: Panel Type Gas Control Device  
Brand: EMS Kontrol  
Model: AR/CR/ER/OR- 711  
Warranty Duration: 2 Years  
Maximum Repair Time: 20 Days  
Banderol and Serial Number:



#### Vendor Company

Title: .....  
Address: .....  
Telephone:..... Faks:.....  
E-Mail:.....  
Invoice Date and Number:.....  
Delivery Date and Place:.....  
Signature of Authorised Person:.....  
Company Stamp:.....

STAMP

#### Product's

Type: Panel Type Gas Control Device  
Brand: EMS KONTROL  
Model: AR/CR/ER/OR- 711

EMS Kontrol reserves the right to make changes and improvements to the product specifications and user manual.

\*For all changes, please visit [emskontrol.com](http://emskontrol.com).